

NOTES

1. THE DESIGN DETAILS SHOWN HEREON SHALL GOVERN THE CONSTRUCTION OF CURBS UNLESS OTHERWISE SHOWN ON PROJECT PLANS.
2. CONCRETE SHALL BE CLASS "C" WITH, 6% ± 2% ENTRAINED AIR.
3. MAXIMUM SPACING FOR CONTRACTION JOINTS SHALL BE 10 FEET.
4. EXPANSION JOINTS SHALL BE PLACED A MAXIMUM OF 30 FEET APART.
5. TRANSVERSE JOINTS IN RIGID PAVEMENTS SHALL BE EXTENDED THROUGH CURBS CONSTRUCTED INTEGRALLY WITH THE PAVEMENT.
6. TYPE "SG" AND "W" MAY BE USED WITH RIGID OR FLEXIBLE PAVEMENTS. TYPE "RG" IS FOR USE WITH REPLACEMENT SECTIONS ONLY.

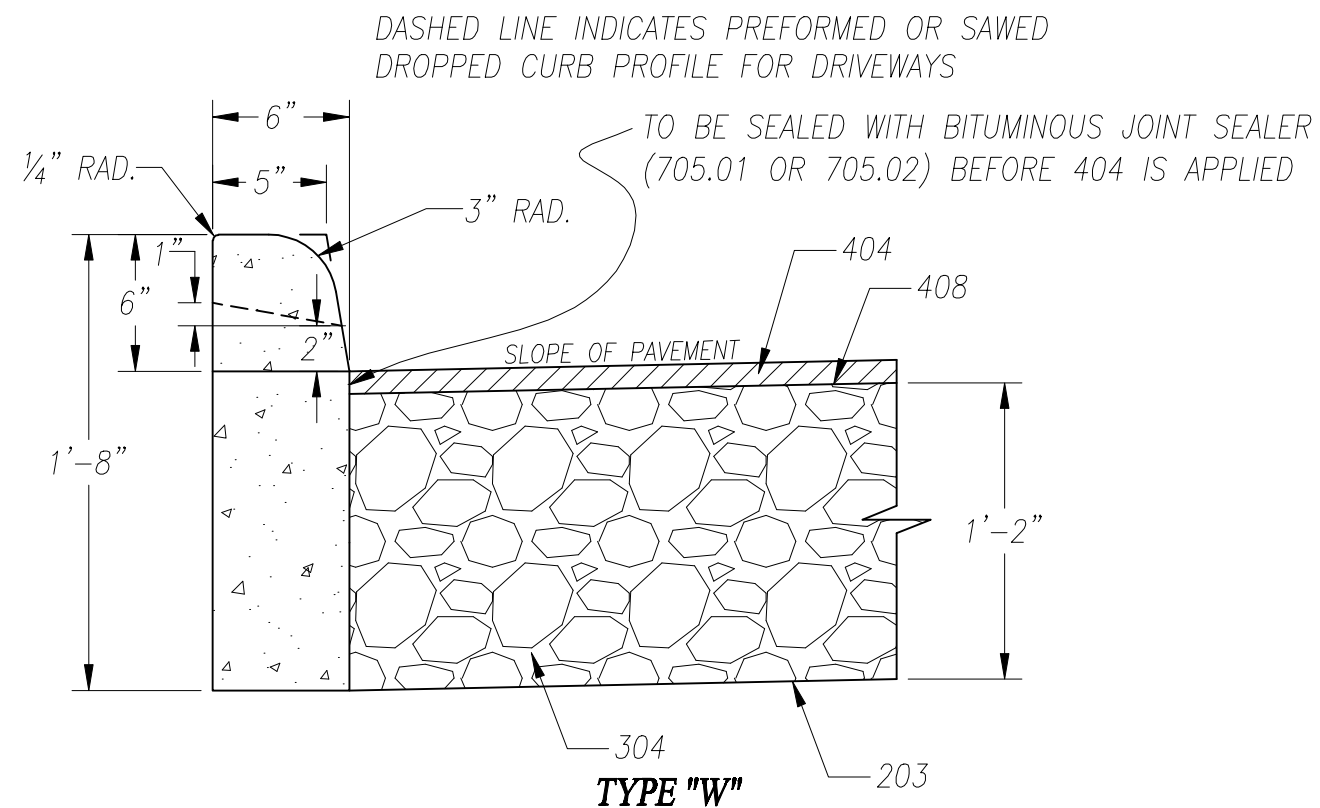

REVISIONS			ALLEN COUNTY, OHIO	
NO.	DATE	BY	COUNTY ENGINEER	
1	6-3-76	TJP	CURB, COMBINATION CURB & GUTTER - CONCRETE TYPE "SG", "RG", & "W"	
2	7-1-76	TJP		
3	6-4-79	TJP		
4	10-3-06	RJM		
			STANDARD CONSTRUCTION DRAWING CC-1	
			DRAWN BY: RJM APPROVED BY: T.J. PIPER	